

PLE
自動校心型

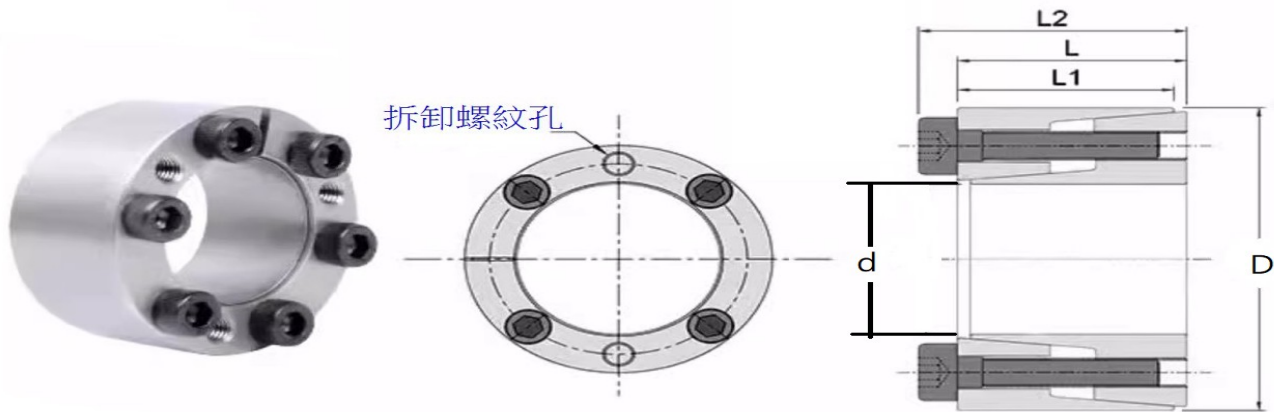

規格	d mm	D mm	L mm	L1 mm	L2 mm	M mm	Ts KN	T Nm	Ms Nm	P N/mm ²
5	5	16	11	10.5	13.5	M2.5	2	6	1.2	55
6	6	16	11	10.5	13.5	M2.5	3	9	1.2	69
6.35	6.35	16	11	10.5	13.5	M2.5	3	10	1.2	72
7	7	17	11	10.5	13.5	M2.5	3	11	1.2	64
8	8	18	11	10.5	13.5	M2.5	3	12	1.2	62
9	9	20	13	12.5	15.5	M2.5	4	17	1.2	60
9.53	9.53	20	13	12.5	15.5	M2.5	4	18	1.2	59
10	10	20	13	12.5	15.5	M2.5	4	19	1.2	60
11	11	22	13	12.5	15.5	M2.5	4	21	1.2	54
12	12	22	13	12.5	15.5	M2.5	4	24	1.2	55
12.7	12.7	23	13	12.5	15.5	M2.5	4	24	1.2	55
14	14	26	17	16.5	0	M3	6	40	2.2	50
15	15	28	17	16.5	0	M3	6	44	2.2	50
16	16	32	17	16.5	21	M4	10	86	5	79
17	17	35	21	20.5	25	M4	10	88	5	56
18	18	36	21	20.5	25	M4	11	94	5	57
19	19	35	21	20.5	25	M4	11	99	5	56
20	20	38	21	20.5	26	M5	17	179	0	89
22	22	40	21	20.5	26	M5	18	187	0	80
24	24	47	26	25	32	M6	24	290	17	79
25	25	47	26	25	32	M6	24	300	17	78
25.4	25.4	47	26	25	32	M6	24	310	17	79
28	28	50	26	25	32	M6	34	480	17	105
30	30	55	26	25	32	M6	34	510	17	95
32	32	55	26	25	32	M6	38	600	17	105
35	35	60	31	30	37	M6	47	820	17	100
38	38	65	31	30	37	M6	47	880	17	92
40	40	65	31	30	37	M6	50	1000	17	99
42	42	75	36	35	44	M8	67	1410	40	99
45	45	75	36	35	44	M8	67	1510	40	99
48	48	80	36	35	44	M8	86	2150	40	123
50	50	80	36	35	44	M8	89	2150	40	118
55	55	85	42	41	52	M8	110	2772	40	174
60	60	90	42	41	52	M8	120	3060	40	166
65	65	95	42	41	52	M8	120	3645	40	174
70	70	110	48	47	58	M10	180	5724	80	182
75	75	115	48	47	58	M10	180	6210	80	129
80	80	120	54	53	65	M10	190	6660	80	130
85	85	125	54	53	65	M10	190	7560	80	123
90	90	130	58	57	0	M10	200	8100	80	121
95	95	135	58	57	70	M10	230	9900	80	140
100	100	145	58	57	70	M12	260	11790	145	186

M: 公制螺絲 Ts: 軸向力 T: 扭矩 Ms: 螺絲扭緊力 P: 輪殼壓力